

Installation Guide and Users Manual

Traffic Guardian speed awareness signs

SP2-12
SP2-12S
SP2-18
SP2-18S

Options:
Battery backup
Solar power

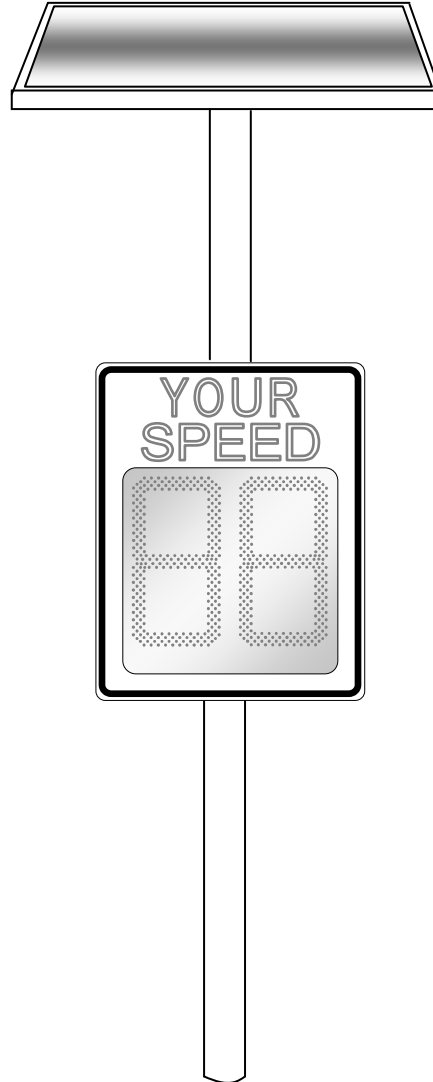

If you have any questions or experience any difficulty operating your SR Products product, contact SR Products Inc. directly.

All warranty information is located at our offices; therefore it is important that you contact us, not your retailer. SR Products, signs are thoroughly tested and inspected prior to shipment, and most issues can be resolved with a phone call. However mishaps do occur, so be sure to fill out and return the warranty card, as any product return is subject to verification of proper return authorization. Information and authorization number may be obtained by writing or calling our offices.

Table of contents

1. Safety Information	2
2. Installation requirements	3
2.1 General information	3
2.2 Site Survey	3
2.3 Pole Selection	3
2.4 Sign mounting bracket	5
2.5 Power/Control Cabinet	Error! Bookmark not defined.
2.6 Sign and Cabinet mounting	Error! Bookmark not defined.
3. Connecting the Sign to the Control Cabinet	5
4. AC powered installation	5
4.1 AC Power only wiring	Error! Bookmark not defined.
4.2 AC powered with Battery Back up	Error! Bookmark not defined.
5. Solar Panel installation	7
5.1 Solar panel mounting	Error! Bookmark not defined.
5.2 Solar panel wiring	Error! Bookmark not defined.
6. Testing the Speed Sign	8
7. Settings / Program control	8
7.1 PC control:	8
7.2 Manual control box:	9
Radar Properties	9
Specifications for the Traffic Guardian SP series Radar Speed Signs	11
Optional Accessories:	12
Limited One Year Warranty	12

1. Safety Information

We provide important safety information and warnings to assist you understanding and avoiding potential harm to yourself and possible damage to the equipment. Although we have included many potential hazards you may encounter when setting up, maintaining and using the equipment, we cannot predict all of the possible hazards that could be encountered and our safety information should not be considered all inclusive and not be a substitute for your good judgment and experience.

Please read and observe all safety information and instructions within this manual prior to using this equipment

Safety messages provide information regarding potential hazards that can cause personal injury to you and others, and are shown in this manual where applicable in the form described below:



WARNING indicates a potentially hazardous situation which, if not avoided, will result in death or serious injury and/or property damage.

CAUTION indicates a potentially hazardous situation which, if not avoided, may result in minor or moderate injury and/or property damage.

2. Installation requirements

This section describes the information you must have available before installing an SR Products driver feedback radar speed sign.

2.1 General information

You will need to address the following items prior and during installation:

1. Any permits needed in your area to install roadside signage is your responsibility.
2. The pole the sign is to be mounted on must meet all local or other governmental requirements.
3. If AC, 120V hardwired, connection wire that meets all applicable electrical codes and any standards established at the installation site must be used.
4. If AC, 120V hardwired, installation by a qualified installer, and a power cut-off switch located in clear sight of the sign is required.
5. Installing the equipment may require working at heights, in which case it is recommended that proper scaffolding or other lifting equipment be used.

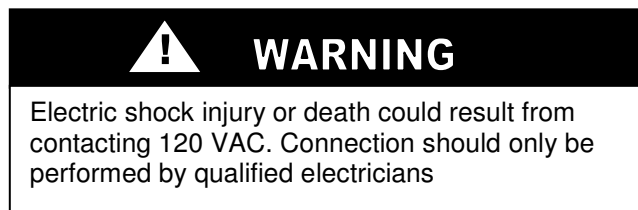

2.2 Site Survey

Before installing the radar speed sign it is important to select a site with the following characteristics to enhance the signs traffic calming effect and sign performance:

- There must be a clear view of the sign for on-coming traffic for a sufficient distance to allow drivers to react if they see an over speed condition. This distance may vary depending on the roadway posted speed limit. Trees, signs or other obstructions as well as curves in the road should be considered.
- Do not install the sign facing an intersection or bridge within the range of the radar, as cross traffic can cause undesired readings.
- Solar panels must have a clear view of the sky, optimally from both rising and setting horizons to provide greatest charge efficiency.

2.3 Pole Selection

Pole selection for the Radar Speed Sign is an important element in the installation design. Selection of the Pole must support the equipment weight as well as the wind loading. The use of breakaway or yielding posts may be required based on federal and local requirements. For roadways with a posted speed limit of 50MPH or greater, the 2003 federal MUTCD specifies a compliance target date in January, 2013 regarding the use of breakaway or yielding sign posts.

To assist in pole selection the radar speed signs have the following physical characteristics. Below shows the weight of a Speed Sign with for an AC powered installation. For a Solar powered installation the battery weight (or any other optional accessory added) must be included for wind / weight loading calculations.

Weight

Product	Weight
SP12x	45 pounds
SP18x	47 pounds

Dimensions:

Fascia size: W x H

Housing dimensions below:

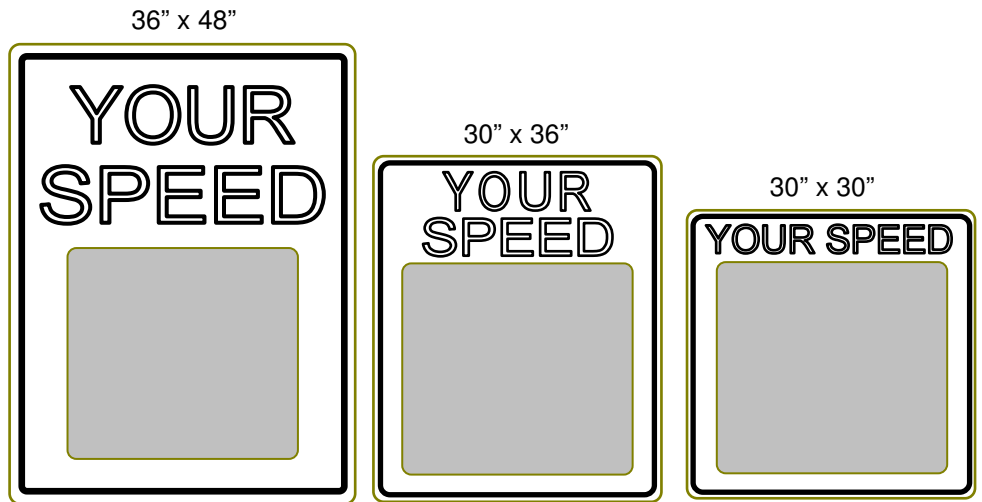
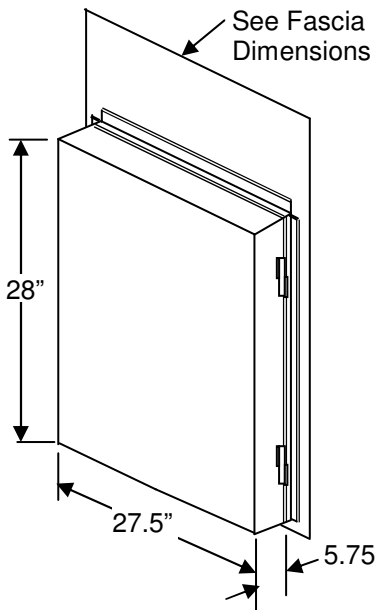

Installations using AC power should include a grounding rod per state and local code. If your installation includes solar power for the radar speed sign, and / or you are adding additional static signage you must include this as part of the pole selection criteria for height and loading requirements.

2.4 Sign mounting

A mounting bracket is included that bolts directly to the back of the radar speed sign. The Bracket is designed to mount to a round pole with a minimum of 4" diameter. Attaching the sign bracket to a pole can be done with banding (not included).

The diameter of the pole determines the size of banding clamps needed.

Typical mounting to a 4" diameter pole is shown below.

The Sign should be mounted at least 6' high from the ground to the bottom of the sign. Check your local or state regulations for the minimum height that may be required.

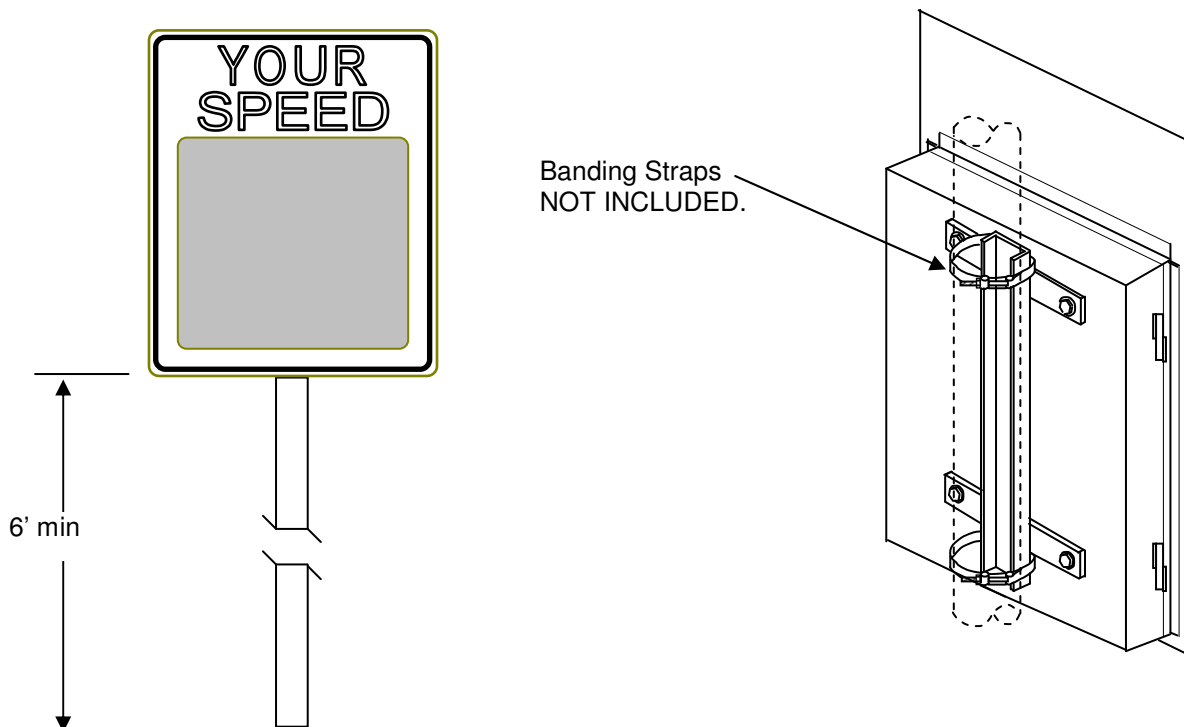

3. AC powered installation

It is the installer's responsibility to ensure that this installation complies with all local and national codes.

Check the installation site for an existing, reliable 120VAC power source. If the site does not have power facilities, new 120VAC power lines must be routed to the site.

! WARNING
Electric shock injury or death could result from contacting 120 VAC. Turn off power before connecting wiring to the AC source.

A 3/4" conduit nipple is provided for routing conduit from a source of AC power to the Display. Follow NEC and local codes. Typically use AWG #14 type THHN 90 degC or better wire pulled through the conduit to the Power / Control Cabinet.

NOTE: The NEC requires that the AC power source be over-current protected using a 15 amp or less fuse or breaker when AWG #14 is used. In addition, a power disconnect must be installed (switch rated breaker is acceptable) that breaks all energized conductors. The disconnect must be within 50 feet and in line-of-sight of the radar speed sign, or must have a lockout mechanism.

Make sure AC Power is off when connecting the power wires. Locate the Junction box mounted inside the Sign, it will be labeled AC Power.

Feed AC power into the cabinet through the 1/2" conduit nipple provided on the back of the cabinet. Remove the junction box cover and connect the AC power wires to the wires in the junction box with wire nuts. The 3 wires in the junction box will be labeled as Hot, Neutral and Ground. Replace the junction box cover.

NOTE: All components requiring power in the box are pre-wired, so the only connections are in the junction box.

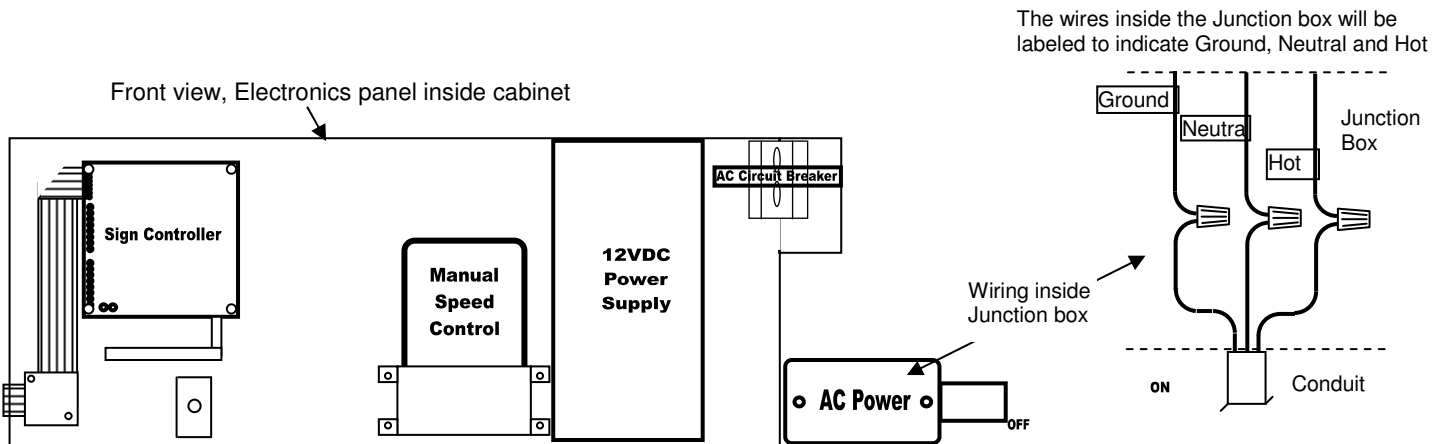

4. Solar Powered Installation

The Solar powered radar speed sign is intended to provide uninterrupted service utilizing solar power only. The solar panel wattage should be selected based on your geographic location, and the application. Typically if the sign is to be for a “school zone” application, the solar panel wattage can be reduced based on the time the sign is actually “on”. Depending on your location you may need to specify a higher wattage solar panel to get satisfactory performance. Some areas in the northern US may not be suitable for year round operation on solar power only.

SR products can provide various solar power options including the mounting brackets based on your requirements.

Solar power requires batteries. The Speed Sign can accept up to six 20AH batteries. Each battery provides approximately 1 day of power (with no power being supplied by the solar panel).

Power from the solar panel is fed through the conduit connector on the back of the Speed Sign. Locate the junction box labeled “Solar Power”, remove the cover and feed the solar panel power cable(s) into the junction box.

Use wire nuts to connect the solar power to the power wires in the junction box as shown below.

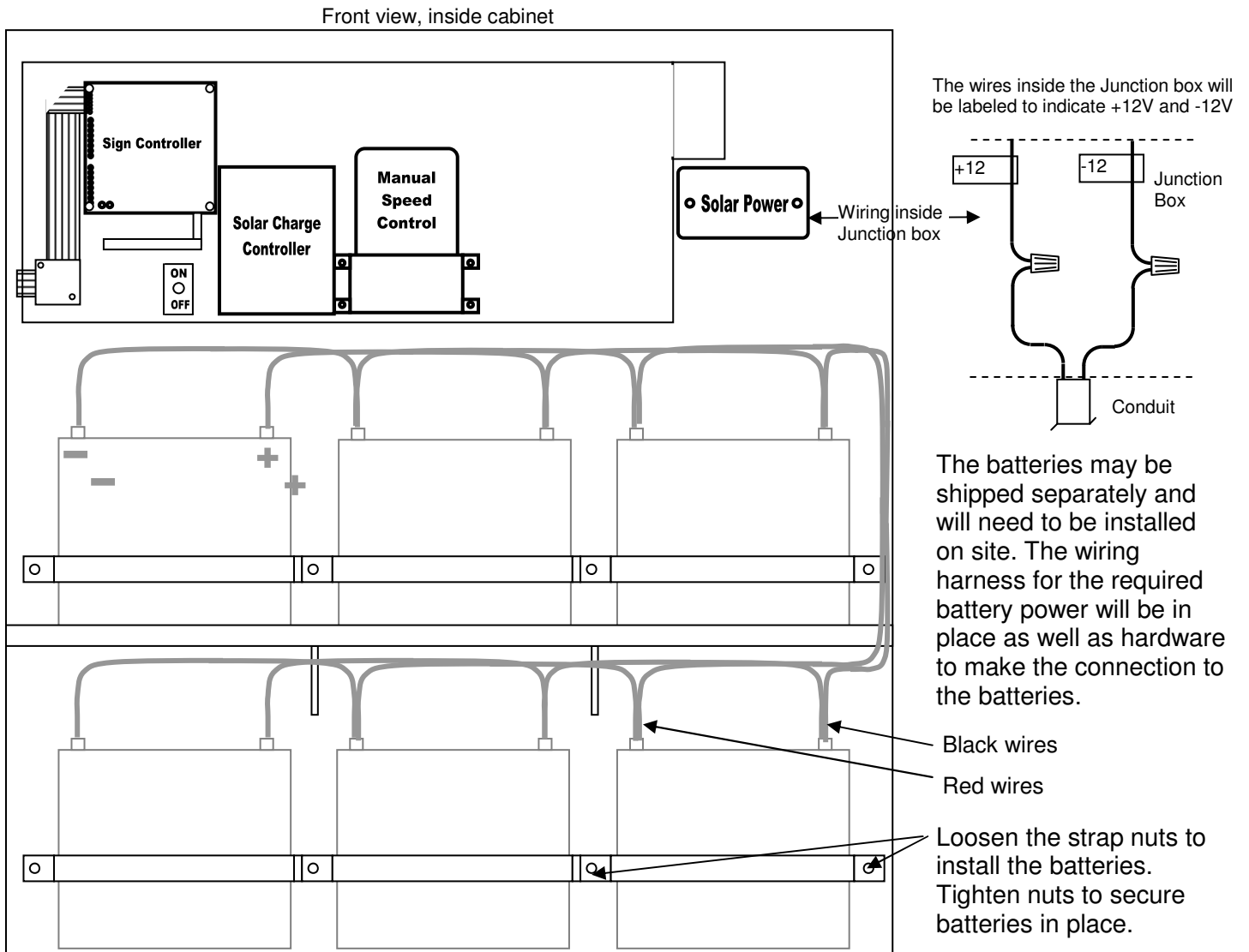

5. Testing the Speed Sign

After Power (either AC or Solar with batteries) has been installed to the Speed Sign you can test the installation.

Open the Speed Sign and turn the display on with the ON/OFF toggle switch. The display should show 88, and a number which represents the current battery voltage. For S models that have the SLOW DOWN text, this will also be displayed on power up. Check that all characters display properly (i.e. all LED's are working).

Move your hand towards the display (at least 5 mph at a few feet away) the display should show 5 or more (the faster you move your hand, the higher the speed) the default units are MPH.

If you have any problem with this check, notify us immediately.

The installation is complete, see the following sections for set up and programming of the radar speed sign to meet your requirements.

6. Settings / Program control

Upon initial installation you will want to set up advanced features of the sign using the computer as described in 6.1.

After the sign has been programmed with your settings, section 6.2 describes manual sign control for setting the speed limits and flash warnings and enable / disable the timer function.

6.1 PC control

The PC Sign control program provides full access to all the radar speed signs capabilities.

Computer requirements: Windows with XP or later operating system.

Installing the Speed Sign Control program:

Insert the SpeedSign Control CD supplied with your radar speed sign in your computer. If the CD does not "auto-launch" in a few seconds, browse to your CD drive and open (double click) the file name "SpeedSignInstallerVx.x.exe".

The program install wizard will prompt you for installation on your computer.

We recommend you use the default settings during program installation.

Once installed, you will see the SpeedSign Control program icon on your desktop.



Sign Control

Before starting the software, you will need to connect the Speed Sign to your Windows computer:

Plug the RF datalink into a USB port on your PC or laptop

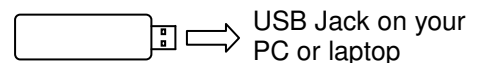

Alternately you can connect a standard A-B type USB cable from the interface panel USB jack to your computer or laptop.

Turn the SpeedSign Power ON with the ON/OFF switch located on the interface panel.

Double click the Speed sign icon to start the program.

At the bottom left in the program window, press the “Find” button. The program will detect Radar Speed signs that are powered up and within range of the RF datalink, which is about 50 feet. Once the program is connected to one or more Speed signs you will be prompt to select the Speed sign you want to set up using the “SpeedSign list” pull down list.

Once selected, the program’s settings windows will populate with the selected SpeedSigns current settings.

Instructions for using the sign control program are available from the program’s “Help” pull down menu.

6.2 Manual control box

The Manual control is located in the Power / Control Cabinet and is connected to the interface panel with a data cable. This control provides ready access to the most commonly used settings:

Speed Limit: Press the + or – buttons to select the desired speed. The limit is the speed at which the sign can flash a warning when exceeded. Typically this would be set to the posted speed limit.

Speed Max: Press the + or – buttons to select the desired speed. Speeds above this setting will not be displayed. NOTE: Some states require speed signs to not display speeds that are over the posted limit by a certain amount. The Speed Max setting should be used in accordance with these regulations.

Flash Warning: Enable or disable the flash warning. When enabled, the sign will flash when a speed is detected that is exceeding set speed limit.

Timer: Enable or disable the timer function. When enabled the sign will turn on and off at the prescheduled times. Disabled, the sign will default to on and function as normal.

Save: Press the Save button after changing any setting(s) to load the changes to the sign. Upon a successful save, the light to the right of the Save button will blink 3 times. If the settings are not successfully saved the sign will **NOT** function based on the settings shown on the control box.

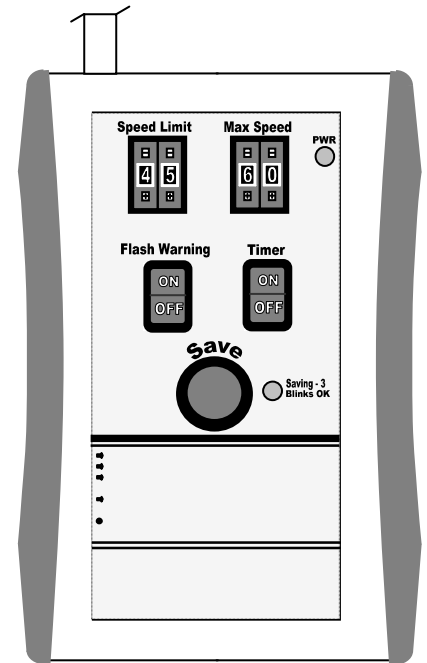

Radar Properties

The Radar and antenna are “directional” in that only vehicles approaching the face of the sign will display a speed.

The angle between a perpendicular line from the display to the line an on-coming vehicle is traveling will affect the registered speed. This is called the cosine error and speeds will be displayed less than their actual speed by multiplying the cosine of the angle by the actual speed.

The distance range of all microwave detectors depends to a large extent on the reflection properties of the measured objects and interference properties of nearby surrounding objects.

The following properties can be expected:

- Vehicles that appear larger and flatter to the microwave beam axis provide a longer radar detection range.

- A less absorbing and scattering reflective surface results in longer range detection.
- As more objects obscure the radar measurement beam the detection zone will become shorter (diffraction scattering, foliage losses, shadow losses and so on).
- Influence by weather, rain and snow lead to absorption losses at the radar detector decreasing the effective range.

Depending upon vehicle type and reflective properties, the typical passenger car will have a detection range of 600 to 800 feet with the signs “long” range setting. For trucks, the distance range is about 50% longer due to the increased reflection area. For motorcycles, distance range is reduced by about 50%.

It is recommended that the Range be set based on the anticipated speed of the traffic. Slow speed limits (i.e under 25MPH) should have a short range setting so as not to display speeds/warnings of possible faster traffic before the imposed speed limit. Mid range setting should be used for speed limits in the 25 to 45MPH speeds, and longer range setting should be selected when the speed limits are above 45 MPH so as to give maximum warning indication time for violators of the speed limit. Table 1 provides some reaction times vs. speed / distances information to assist in selecting the range setting based on the anticipated vehicle speeds.

TABLE 1: warning times (in Seconds) based on vehicle speed and range.

	5 MPH	10 MPH	20 MPH	30 MPH	40 MPH	50 MPH	60 MPH	70 MPH
100 FT	13.6	6.8	3.4	2.3	1.7	1.4	1.1	1.0
500 FT	68.2	34.1	17.0	11.4	8.5	6.8	5.7	4.9
1000 FT	136.4	68.2	34.1	22.7	17.0	13.6	11.4	9.7

Specifications for the Traffic Guardian SP series Radar Speed Signs

Radar Speed Display		
	SP2-12x	SP2-18x
Display Type	2 digit, 7 Segment yellow LED	
Character height	12 inches	18 inches
Readable distance	600 feet	1000 feet
Dimensions	21-1/8" W x 15-3/4" H x 2" D	26-1/2" W x 21-1/2" H x 2 D
Weight	14 pounds	20 pounds
Voltage	12VDC nominal (Minimum 10.0 VDC to Maximum 16.6 VDC)	
Max power	28 Watts	40 Watts
Frame material	Aluminum	
Bracket material	Aluminum	
Hardware	Stainless steel	
Frame finish	Heat cure Powder coat	
Lens material	1/4" thick, UV protected Impact resistant Lexan tinted for anti-glare	
Radar	K-Band dual mixer with planar antenna 12 x 24 deg	

Power / Control Cabinet	
Dimensions	14" W x 17" H x 10-1/2 D
Weight	22 pounds
Box Material	Aluminum
Bracket Material	Aluminum
Hardware	Stainless Steel
Box Finish	Polished Aluminum
AC Power Option	
AC input	Supplied by Installer, 100 to 240 VAC, 50 / 60 Hz, 2A min
DC PS	12VDC Power supply, 120W SP18(x), 60W SP12(x)
Circuit breaker	10A, 120 / 240 VAC UL1077

Battery back-up for the AC power option	
Battery	18Ah SLA battery
Charger	Smart charger, 5A max output
Back-up time	Typical: 12 hours for the SP12x and 8 hrs for the SP18x

Solar power	
Wattage	60W included, suited for limited on time applications
Charge controller	10A, 12VDC with LV cutoff and auto re-start.
Battery	35Ah SLA with SP12(x) and 55Ah SLA with SP18(x)
Battery life No sun	Approximately 3 days On time starting with full charge
Battery life ⁽¹⁾ On Continuously	Approximately 10 days On time.
Battery Life ⁽¹⁾ Limited On time	Continuous operation at 4 hours per day or less On time.

(1) With 75% sunny days, and below 40 Deg latitudes, starting with full battery charge.

NOTE: On time for battery life estimates are based on 90% of the time the sign is displaying speeds during the day and 30% at night.

Optional Accessories:

Field interchangeable items:

Part# SL-xx	Speed Limit signs, select from xx= 05 to 75 in 5MPH increments. (KPH available on special order)
Part# SM-xx	Custom message sign 8" x 24".
Part# BT-55	Replacement Battery 55 A/h for SC18(x) Solar powered signs
Part# BT-35	Replacement Battery 35 A/h for SC12(x) Solar powered signs
Part# BT-18	Replacement Battery 18 A/h for back-up for AC powered signs
Part# DS-01	Data Storage: Can store over 10 years of date and time stamped speed data to a micro SD card.
Part# SP-120	120W solar panel power system upgrade

Limited Two Year Warranty

The Traffic Guardian Radar Speed Sign comes with a factory two-year warranty on all parts and labor for workmanship and premature component failure. Warranty shipment costs are not pre-paid. This warranty does not include repair of physical damage from misuse or vandalism. This product is warranted to be free of manufacturing defects for a 2-year period from the original date of purchase. The warranty does not include damage to the product resulting from accident, misuse, improper installation, operation, or unauthorized repair or alteration. Opening the product case will void this warranty. If the product should become defective within the warranty period, SR Products Inc., will repair or replace it at our option, free of charge. You must fill out and return the product registration to ensure warranty coverage failure to fill out registration form may void warranty. To obtain warranty service, first contact SR Products warranty repair department, then upon approval send the unit at purchaser's cost to:

SR Products Inc., 7379 S. Suncoast Blvd. Homosassa, FL 34446

Return shipping to purchaser will be at SR Products Inc.'s, cost inside the 48 continental United States, international shipping is the sole responsibility of the purchaser.

The consumer's sole remedy shall be such repair or replacement as is expressly provided above, and we shall in no event be liable for any incidental or consequential damages arising out of the use or inability to use this product for any purpose whatsoever. Some states do not allow the exclusion or limitation of incidental or consequential damages, so the above limitation or exclusion may not apply to you. This warranty gives you specific rights. You may also have other rights, which vary, from state to state. Unauthorized returns will be refused.